

ABOVE GROUND HYDRANT TYPE BREAK AWAY DN 150

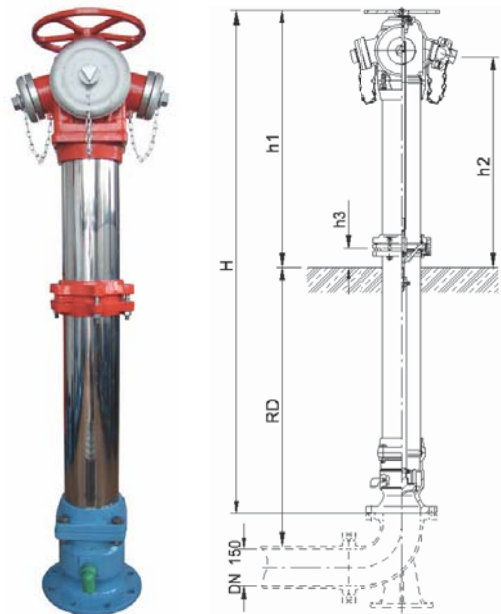

Material: Ductile cast iron GJS / Steel
 Protection: Fluidized bed epoxy powder coating
 Nominal pressure: PN 10/16 bar



Code	DN	RD	Sockets			Hydrant body			Weight (kg)
			A	B	C	H (mm)	h1 (mm)	h2 (mm)	
2501804	150	1000	-	2	-	2000	1120	920	76
2501801	150		1	2	-				
2501805	150	1250	-	2	-	2250	1120	920	78
2501802	150		1	2	-				
2501806	150	1500	-	2	-	2500	1120	920	81

installation recommendation for break point: h3 = 120 ± 50 mm.

Technical data:

Above ground hydrant in standard version has: wedge of ductile cast iron GJS complete rubberized, with automatic inlet-outlet air valve. Drain off system is automatic after every usage, wedge is so design according to seat of hydrant, so that provide that flow of fluid is in linear function.

Head cover is made according international standards which enable usage of standard operating keys for hydrants or operating with hydrant wheel.

According request of customers, we deliver hydrants with safety couplings (HAWLE couplings).